

Series 16 Modules Controls – Solid State Plug-In Modules

- ▶ Compact Size
- ▶ Modular Plug-in Design
- ▶ CSA Approved
- ▶ U.L. “Motor Control”
- ▶ Solid State Reliability
- ▶ LED Monitoring
- ▶ Various Time Delays
- ▶ Low Voltage Sensor

Series 16M – General Purpose Control

- New Microprocessor Design

Designed for either differential or single-level service. U.L. “Motor Controller” listing, CSA. 8 pin socket with screw-type connections make the unit easy to install and service. Sensitivity of up to 1 million ohm/cm.

Series 16HM – High Sensitivity Control

Series 16HM is similar to Series 16M but provides higher sensitivity up to 5.5 million ohm/cm. Probe voltage is 12 VDC for applications with low conductive media.

Series 16DM – DPDT Load Contact

Similar to Series 16M but with DPDT load contacts. Eliminates the need for slave relays. 11 pin octal plugs. Requires little panel space. General purpose single-level or differential applications. U.L., CSA listed.

Series 16VM – Field Selectable Sensitivity

Similar to Series 16M but with the added flexibility of field adjustable sensitivity, made possible through external setpoint resistors. Uses 11 pin octal socket. U.L., CSA listed.

Specifications

Contact Design	
Series 16M & 16HM	1 N.O. & 1 N.C. (1 form C)
Series 16DM	2 N.O. & 2 N.C. (2 form C)
Series 16VM	1 N.O. & 1 N.C. (1 form C)
Contact Rating (120. 240 VAC)	
Series 16M & 16HM	10 amp Resistive 1/3 hp
Series 16DM	5 amp Resistive 1/10 hp
Series 16VM	10 amp Resistive 1/3 hp
Mode of Operation	Direct/Inverse, factory set
Sensitivity	
Series 16M	0-1M ohm, factory set
Series 16HM	0-5.5M ohm, factory set
Series 16DM	0-1M ohm, factory set
Series 16VM	0-1M ohm, field adjustable
Primary Voltage	24 VAC, 120 VAC, 240 VAC (+10%/-15%) 208/240: 187 V min. to 255 V max. VAC 50/60 Hz
Secondary Voltage	
Series 16M	12 VAC, 1.5 mA
Series 16HM	12 VDC
Series 16DM & 16VM	12 VAC, 1.5 mA
Temperature	-40°F to 150°F (-40°C to 65°C)
Approvals	U.L. 508 File #E44426; CSA
Terminal Style	Screw connector
Options	Time Delays

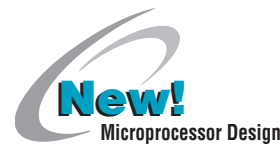

Series 16M/16HM



Series 16DM/16VM

Applications

- Single-Level Service
- Point Level
- Valve Control
- Differential Service
- Alarms
- Pump Control

Dimensions

Series 16M & 16HM

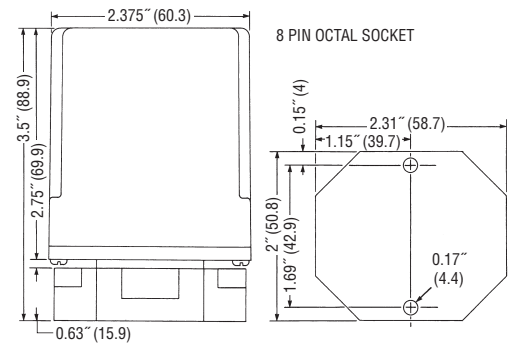

Series 16DM & 16VM

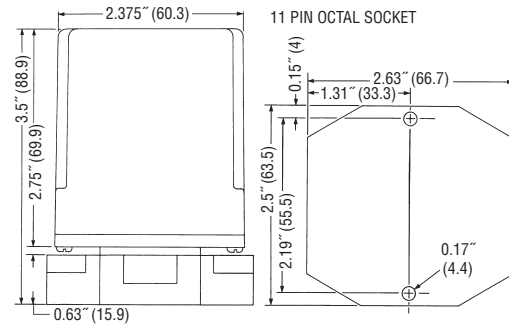

Note: Controls also available with DIN mount socket.

Wiring

Series 16M & 16HM

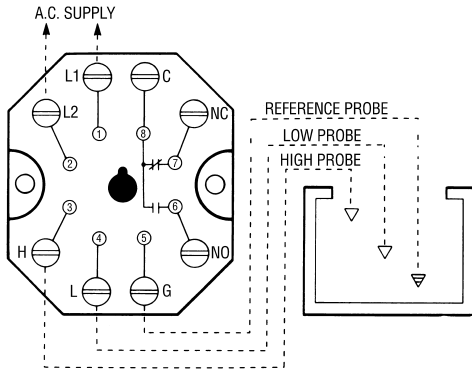

Note: For single level service, use "H" and "G" connections.

Series 16DM

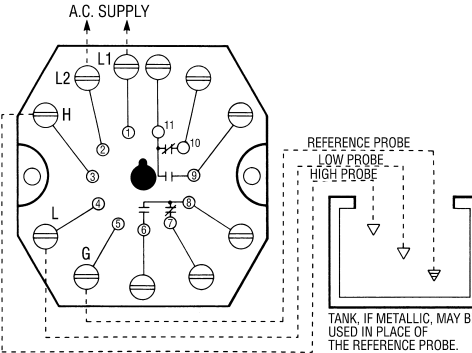

Series 16VM

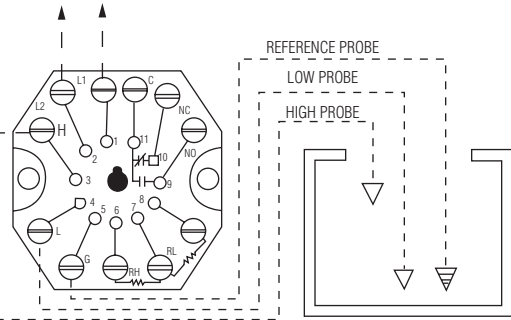

Variable Sensitivity Option

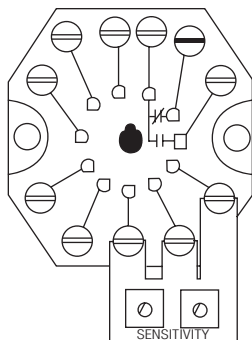

Part number 16Z1VG Potentiometer Board available for 16VM only. Consult factory.

How to Order

Use the **Bold** characters from the chart below to construct a product code.

16M Series – Microprocessor Version

	16M	X	X	X	X	X	XX	XX
1. Series	_____							
	16M General Purpose;							
2. Mode of Operation	_____							
	Direct				Inverse			
	A – 4.7K	E – 100K	K – 4.7K	P – 100K	L – 10K	R – 470K	M – 26K	S – 1M
	B – 10K	F – 470K	N – 50K					
	C – 26K	G – 1M						
	D – 50K							
3. Supply Voltage	_____							
	1 120 VAC; 2 240 VAC; 3 24 VAC; 8 208/240 VAC							
4. Socket Style*	_____							
	A 8 Pin Octal				M Module Only			
	B 8 Pin DIN							
5. Enclosure	_____							
	0 None; 1 NEMA 1; 4 NEMA 4							
6. Time Delay (increasing level) Option	_____							
	00-90 seconds							
	Blank 0 seconds							
7. Time Delay (decreasing level) Option	_____							
	00-90 seconds							
	Blank 0 seconds							
8. Dirty Probe/ Time Out Option	_____							
	See page D-36, Chart A							

*See page D-37 for descriptions.

16 HM, 16DM or 16VM Series

	16HM	X	X	X	X	XX	XX
1. Series	_____						
	16HM High Sensitivity;						
	16DM DPDT Load Contact;						
	16VM Field Selectable Sensitivity ¹						
2. Mode of Operation ²	_____						
	Direct			Inverse			
	A – 4.7K ⁴	F – 470K ⁴	K – 4.7K ⁴	R – 470K ⁴	L – 10K ⁴	S – 1M ⁴	M – 26K ⁴
	B – 10K ⁴	G – 1M ⁴	N – 50K ⁴	W – 5.5M ³	H – 3M ³	T – 3M ³	Z – 0-700K ⁵
	C – 26K ⁴	I – 5.5M ³	P – 100K ⁴				
	D – 50K ⁴	Y – 0-700K ⁵					
	E – 100K ⁴						
3. Supply Voltage	_____						
	1 120 VAC; 2 240 VAC; 3 24 VAC; 8 208/240 VAC						
4. Socket Style*	_____						
	A 8 Pin Octal (16M & 16HM), 11 Pin Octal (16DM & 16VM);						
	B DIN Mount; M None, Module Only ⁶						
5. Enclosure	_____						
	0 None; 1 NEMA 1; 4 NEMA 4						
6. Time Delay (increasing level) Option	_____						
	01-20 seconds; 0V variable (16VM only)						
7. Time Delay (decreasing level) Option	_____						
	01-20 seconds; 0V variable (16VM only)						

*See page D-37 for descriptions.

Notes:

- 16VM select modes **A**, **K**, **Y** or **Z** only.
- 16HM & 16DM only. Series 16VM includes full set of the resistors listed above. Specify a sensitivity to determine mode of operation.
- 16HM only.
- All Series except 16HM.
- 16DM only.
- Socket style M requires enclosure **0** – None.

Socket Details and Option Availability are located on page D-36 and D-37.