



Model 764T

MODEL 764T TEMPERATURE CONTROLLER

The Model 764T is a pneumatic temperature controller. It measures the temperature of the fluid with a bimetallic bulb and develops a 3-15 psig (0.2-1.0 Barg) output signal that varies linearly with any change in temperature. The 764T controls temperatures between -70° and $+580^{\circ}\text{F}$ (-60° and $+305^{\circ}\text{C}$) using six ranges.

FEATURES

- Adjustments:** Proportional band and setpoint.
- Field Reversible:** Easily changed from direct acting to reverse acting.
- Two Bulb Materials:** 316SST or brass thermal bulbs.
- Gauge:** 1-1/2" (38 mm) output signal gauge.

APPLICATIONS

Designed to control temperature in bleachers, cookers, dryers, evaporators, heaters, heat exchangers, kilns, mangles, molding machines, presses, retorts, sterilizers, stills, vats, washers, et cetera.

SPECIFICATIONS

Control Ranges: -70° to +100°F (-60° to +35°C)
 50° to 220°F (10° to 105°C)
 180° to 350°F (80° to 175°C)
 See Option 764T-63 for higher temperature ranges.

Thermal Bulb Materials: Brass - ASTM B16 and B135 with Invar Rod
 316 SST - ASTM A479 with Invar rod.

Thermal Bulb Connection: 1/2" NPT.

Maximum Operating Pressure: 3000 psig (207 Barg) at 350°F (177°C) for brass and SST thermal bulbs.

Maximum Emergency Temperature: 450°F (232°C) with standard construction.
 850°F (454°C) with Option 764T-63.

Control Housing Sub-Assembly: Brass housing, Buna-N O-ring seals, SST adjusting screws, etc.

Output Range: 3-15 psig (0.2-1.0 Barg).

Supply Pressure: 18-20 psig (1.2 -1.4 Barg).

Output Signal Gauge: 0-30 psig (0-2.1 Barg) range.

Ambient Temperature Range: -20° to +180°F (-28° to +82°C).

Proportional Band: Adjustable between 6° and 32°F (3 and 18°C) with 18-20 psig (1.2-1.4 Barg).

Sensitivity: Better than 0.2°F (.1°C).

Repeatability: ±0.8°F (±.45°C).

Steady State Air Consumption:

Flow Rate*	Prop. Band
SCFH (M ³ /Hr. @ Msc)	°F (°C)
4.2 (0.12)	6 (3)
50 (1.41)	32 (18)

*Mid-span at proper supply.

Air Connections: 1/4" NPT female pipe connections.

Typical Installations: See Figures 3, 4, and 5.

OPTIONS

Option-63: HIGH TEMPERATURE EXTENSION. 316SST thermal bulb for temperatures above 350°F (175°C). See Figure 1.

Temperature Range	
°F	°C
380 to 540	190 to 280
400 to 560	205 to 295
430 to 580	220 to 305

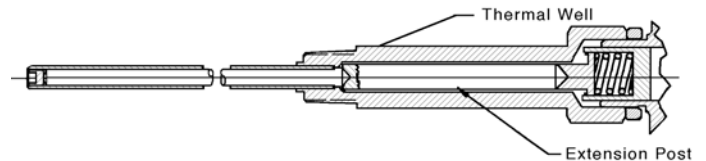

Figure 1
 High Temperature Thermal Bulb (Opt. 63).

Option-64: THERMAL WELL. Brass or 316SST thermal well for use with 316SST thermal bulbs, both standard and high temperature (Option 764T-63). 3/4" NPT connection to process piping. Maximum static pressure 1000 psig (68 Barg) at 400°F (204°C) for brass and 6200 psig (427.6 Barg) at 580°F (305°C) for 316SST thermal well.

ACCESSORIES

Volume Booster: 1:1 ratio for improving the stroking speed of diaphragm motor vales when no positioner is used. Incorporates a stabilizing bypass needle valve between input and output (Moore Products - Model 61H).

Air Filter Regulator: Model 5100P. 1/4" NPT male connections with 1-1/2" (38 mm) supply pressure gauge.

PRINCIPLE OF OPERATION

The 764T controller employs laminar flow to develop the 3-15 psig (2.07-1.03 Barg) output signal. Laminar flow eliminates the need for range springs, levers, pivots and other parts that produce friction and lost motion.

A bimetallic thermal bulb is used to measure temperature. It is immersed in the fluid whose temperature variation changes the length of the outer tube more than it changes the length of the Invar rod. This difference produces a minute movement of the end of the Invar rod that contacts the sensor plate. The sensor plate, in turn throttles the flow of instrument air through the sensor to develop the 3-15 psig (2.07-1.03 Barg) output signal.

On direct acting controllers, see Figure 2, the supply enters PORT B. With an increase in the sensed temperature the supply air flowing through the sensor orifice increases,

which elevates the output signal. The proportional band restriction regulates the flow of exhaust through PORT A.

On reverse acting controllers the supply enters PORT A and passes through the proportional band restriction. With an increase in the sensed temperature the flow through the sensor orifice is increased, which reduces the output signal. PORT B is the exhaust port.

Closing the proportional band adjusting screw reduces the proportional band. Opening the screw increases the proportional band.

The setpoint adjustment moves the sensor closer to, or further away from, the sensor plate to change the controlled temperature.

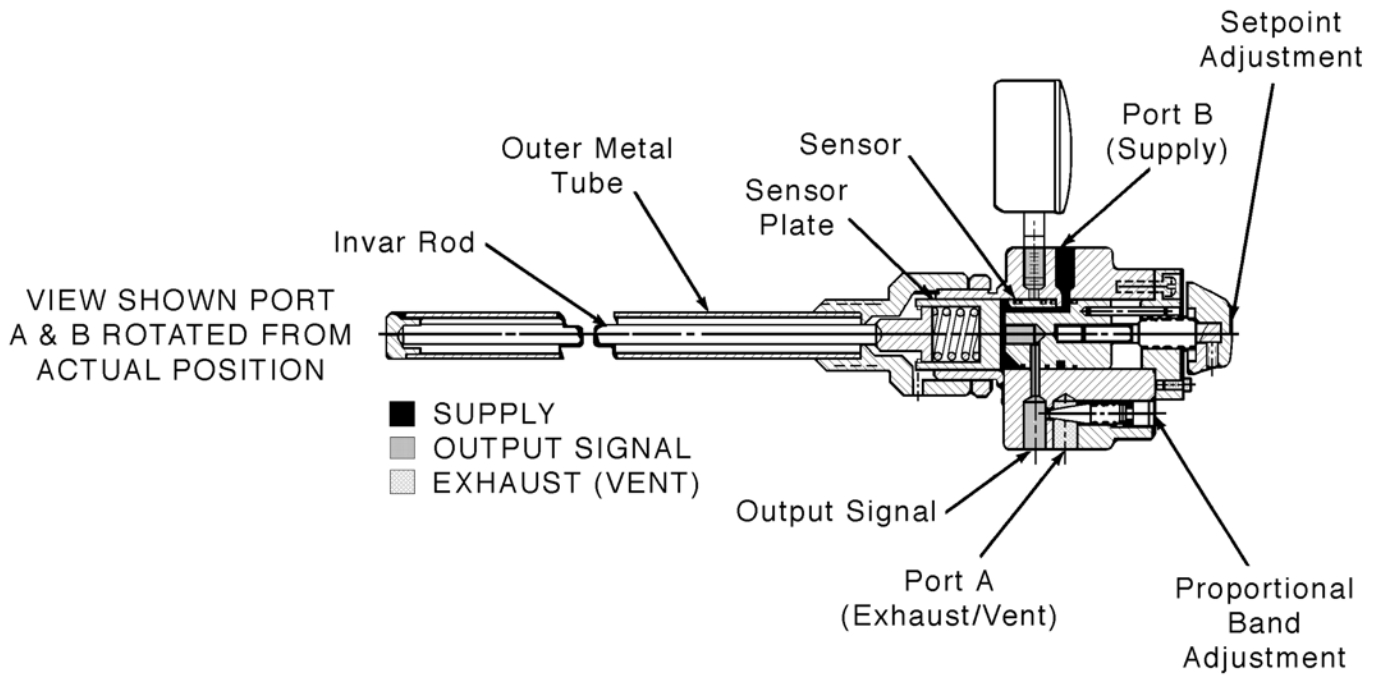

Figure 2
Direct Action 764T

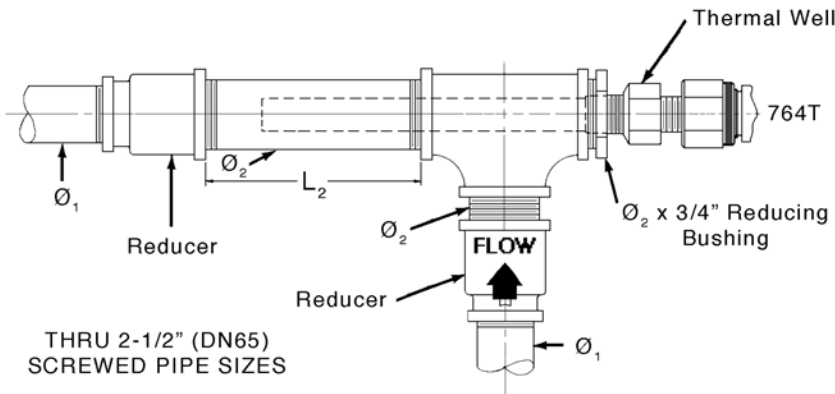
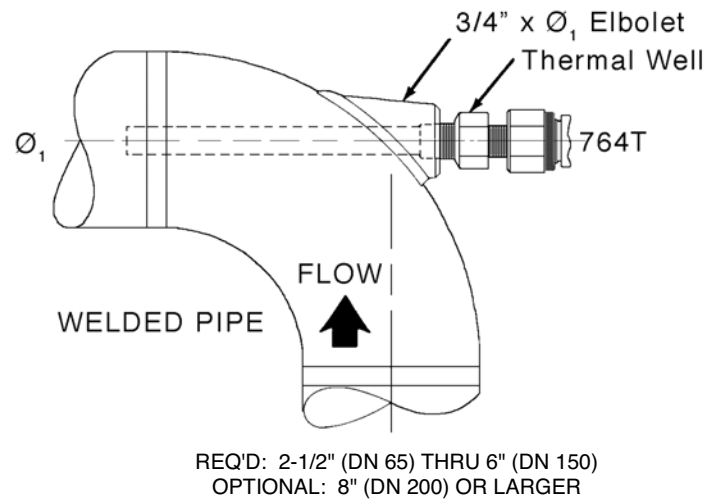
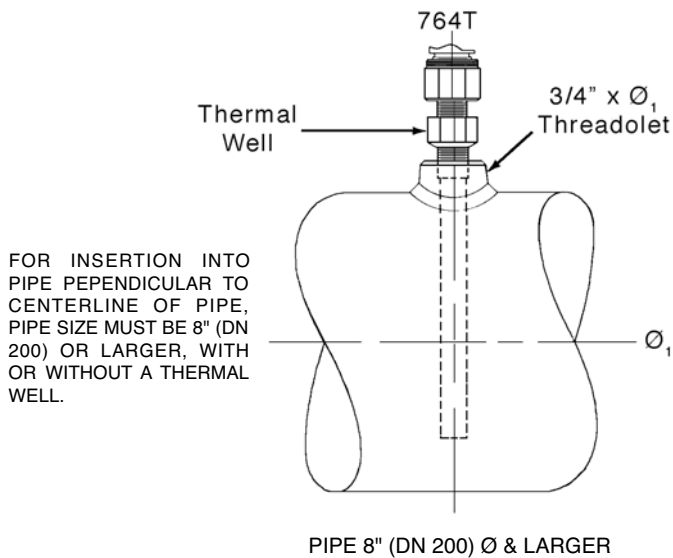
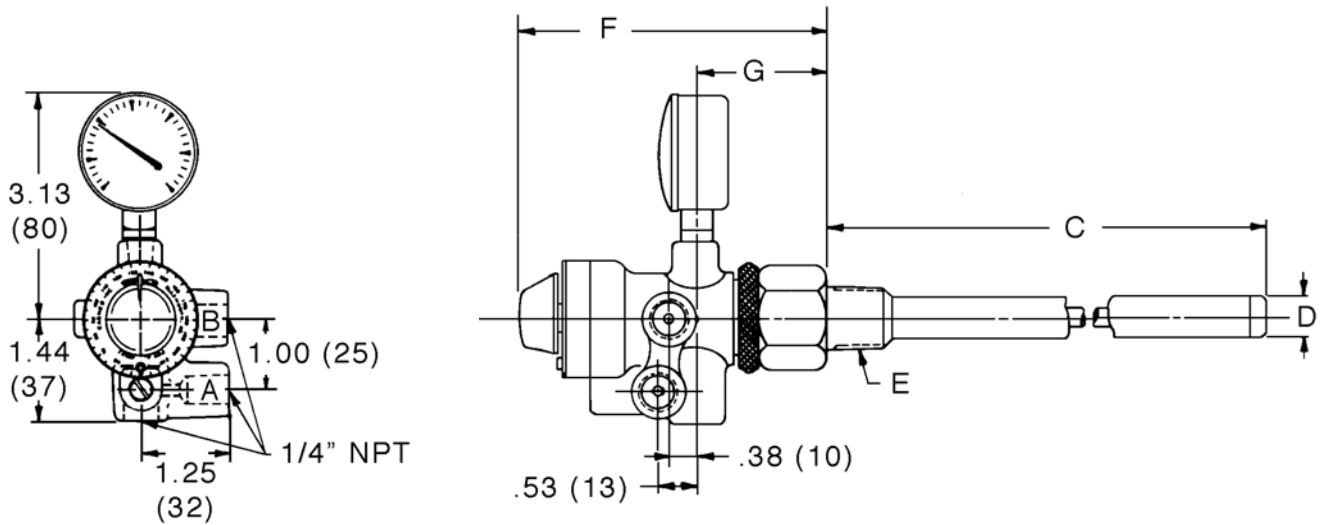

Figure 3

ϕ_1	ϕ_2	Nipple Length L_2
Inch (mm)	Inch (mm)	Inch (mm)
1/2" (DN15)	1" (DN25)	6" (152)
3/4" (DN20)	1-1/4" (DN32)	
1" (DN25)	1-1/4" (DN32)	
1-1/4" (DN32)	1-1/2" (DN40)	
1-1/2" (DN40)	2" (DN50)	
2" (DN50)	2" (DN50)	NR
2-1/2" (DN65)	2-1/2" (DN65)	
NR = Not Required.		



DIMENSIONS



Dimension	Brass Thermal Bulb		SST Thermal Bulb		764T-63 High Temp. Thermal Bulb		764T-63+64 High Temp. & Thermal Well		764T-64 Thermal Well	
	Inches	mm	Inches	mm	Inches	mm	Inches	mm	Inches	mm
C	7.75	196	8.88	226	8.88	226	8.50	216	8.50	216
D	0.56	14	0.37	9	0.37	9	0.77	20	0.77	20
E	1/2 NPT	DN15	1/2 NPT	DN15	1/2 NPT	DN15	3/4 NPT	DN20	3/4 NPT	DN20
F	4.25	108	4.25	108	7.75	197	8.88	226	5.38	137
G	1.81	46	1.81	46	5.31	135	6.44	164	2.94	75

NOTES

NOTES

NOTES

PRODUCT CODE 02/12/04

TABLE 1 - TEMPERATURE RANGE			
Std. Temp Range - BR or SST Bulb	CODE	High Temp Range - SST Bulb (-63 Opt)	CODE
-70° to +100F	1	380° to 540°F	4
50° to 220°F	2	400° to 560°F	5
180° to 350°F	3	430° to 580°F	6
10° to 105°C	A	190° to 280°C	E
-60° to +35°C	B	205° to 295°C	F
80° to 175°C	C	220° to 305°C	G

TABLE 2 - MATERIALS				
Applicable Temp Ranges (°F)	Thermal Bulb Material	Thermal Well (-64 Opt)		
		None	Brass	316 SST
		CODE	CODE	CODE
Standard (-70° to +350°)	Brass	B0	--	--
	316 SST	S0	SB	SW
Hi-Temp (-63 Opt) (380° to 580°)	Brass	--	--	--
	316 SST	H0	--	HW

3-15 psig Signal Output



Model 764T Pneumatic Temperature Controller

TABLE 4 - OPTIONS	
When ordering a valve per one of Cashco's special drawings, use the code "X" and the 5-digit number following. Otherwise, add "0" to all unused squares.	
Construction	CODE
Special Construction	X
No Special Construction	0

TABLE 3 - ACCESSORIES	
Unmounted Airset (Shipped Loose)	
Description	CODE
No Airset	0
5100P Airset (Filter Regulator) 0-30 psig range (w/gauge)	A